

APRIL 2021
05-1007-000

Xerox[®] D35 Scanner

Scanner User Guide for Microsoft[®] Windows.

© 2021 Xerox Corporation. All rights reserved. Xerox® is a trademark of Xerox Corporation in the United States and/or other countries. Visioneer is a trademark licensee of Xerox®.BR32863

Content © 2021 Visioneer, Inc. All rights reserved. The Visioneer brand name and OneTouch® logo are registered trademarks of Visioneer, Inc.

Reproduction, adaptation, or translation without prior written permission is prohibited, except as allowed under the copyright laws. Copyright protection claimed includes all forms of matters of copyrightable materials and information now allowed by statutory or judicial law or hereinafter granted, including without limitation, material generated from the software programs which are displayed on the screen such as styles, templates, icons, screen displays, looks, etc.

Document Version: 05-1007-000 (April 2021)

Adobe®, Adobe® Acrobat®, Adobe® Reader®, and the Adobe® PDF logo are registered trademarks of Adobe Systems Incorporated in the United States and/or other countries.

Post-It® is a registered trademark of 3M in the United States and/or other countries.

Microsoft is a U.S. registered trademark of Microsoft Corporation. Windows™ and SharePoint® are registered trademarks of Microsoft Corporation.

TWAIN™ is a trademark of TWAIN Working Group.

Intel® and Pentium® are trademarks of Intel Corporation in the United States and/or other countries.

Universal Serial Bus is a trademark of USB Implementers Forum, Inc. (USB-IF).

All other products mentioned herein may be trademarks of their respective companies and are hereby acknowledged.

Changes are periodically made to this document. Changes, technical inaccuracies, and typographic errors will be corrected in subsequent editions. Information is subject to change without notice and does not represent a commitment on the part of Visioneer.

The software described is furnished under a licensing agreement. The software may be used or copied only in accordance with the terms of such an agreement. It is against the law to copy the software on any medium except as specifically allowed in the licensing agreement. No part of this document may be reproduced or transmitted in any form or by any means, electronic or mechanical, including photocopying, recording, or information storage and retrieval systems, or translated to another language, for any purpose other than the licensee's personal use and as specifically allowed in the licensing agreement, without the express written permission of Visioneer.

Restricted Rights Legend

Use, duplication, or disclosure is subject to restrictions as set forth in contract subdivision (c)(1)(ii) of the Rights in Technical Data and Computer Software Clause 52.227-FAR14. Material scanned by this product may be protected by governmental laws and other regulations, such as copyright laws. The customer is solely responsible for complying with all such laws and regulations.

Table of Contents

1 Safety.....	1-1
Safety Introduction.....	1-1
Operational Safety Information	1-1
Electrical Information	1-2
Warning - Electrical Safety Information.....	1-2
Electrical Supply.....	1-2
Disconnect Device	1-3
Emergency Power Off	1-3
Maintenance Information	1-3
Product Safety Certification.....	1-3
Environmental Health and Safety Contacts	1-4
2 Welcome.....	2-1
What's in the Box.....	2-1
System Requirements	2-1
A VGA or SVGA Monitor:.....	2-2
Documentation.....	2-2
Xerox® D35 Scanner.....	2-3
3 Scanner Setup	3-1
Connect the Scanner Power Supply.....	3-1
4 PC Installation.....	4-1
Install the Software and Connect the Scanner.....	4-1
Installing the Scanner Driver	4-3
Connect the USB Cable and Turn on the Power	4-4
Installing Visioneer OneTouch.....	4-5
Installing Additional Applications	4-6
View the User Guides	4-6
Register Your Scanner	4-7
5 Loading Documents to Scan	5-1
Supported Document Types.....	5-1
Documents to Avoid Scanning.....	5-2
Unsupported Document Types	5-2
Scanning from the Automatic Document Feeder (ADF).....	5-3
Preparing Documents for Scanning.....	5-3
Loading Documents.....	5-3
Scanning Interfaces.....	5-4

6 Scanner Options, Maintenance and Troubleshooting	6-1
Safety Precautions.....	6-1
Hardware Properties	6-1
Device Settings.....	6-2
Driver Settings	6-3
HW IP Settings	6-3
Clearing Paper Jams	6-3
Cleaning the Scanner.....	6-4
Cleaning the Outside of the Scanner	6-4
Cleaning the Inside of the Scanner	6-4
Cleaning the ADF Rollers	6-5
Cleaning the Scanner Glass and Background Plates.....	6-6
Cleaning the Paper Sensors.....	6-7
Cleaning the ADF Sensors.....	6-7
Replacing the Rollers	6-8
Replacing the Feed Roller.....	6-9
Replacing the Friction Roller.....	6-10
Error Light Troubleshooting Codes.....	6-12
Troubleshooting	6-13
Uninstalling Your Scanner.....	6-15
Xerox® D35 Scanner Specifications	6-16
Xerox® D35 Scanner Parts List.....	6-18
7 Appendix A: Regulatory Information	7-1
Basic Regulations.....	7-1
United States (FCC Regulations)	7-1
Great Britain.....	7-1
European Union.....	7-2
Turkey (RoHS Regulation)	7-2
Copy Regulations.....	7-2
United States	7-2
Canada.....	7-4
Other Countries.....	7-4
8 Appendix B: Compliance Information	8-1
Product Recycling & Disposal	8-1
USA & Canada	8-1
European Union.....	8-1
ENERGY STAR for the USA.....	8-1

1. Safety

Safety Introduction

Notices and Safety

Please read the following instructions carefully before operating the machine and refer to them as needed to ensure the continued safe operation of your machine.

Your Xerox® Product and supplies have been designed and tested to meet strict safety requirements. These include safety agency evaluation and certification, and compliance with electromagnetic regulations and established environmental standards.



The safety and environment testing and performance of this product have been verified using Xerox® Materials only. Unauthorized alterations, which may include the addition of new functions or connection of external devices, may impact the product certification. Please contact your Xerox representative for more information.

Operational Safety Information

Your Xerox® Equipment and supplies have been designed and tested to meet strict safety requirements. These include safety agency examination, approval, and compliance with established environmental standards.

To ensure the continued safe operation of your Xerox® Equipment, follow these safety guidelines at all times:

Do these:

- Always follow all warnings and instructions that are marked on or supplied with the equipment.
- Always use materials specifically designated for this product, the use of other materials may result in poor performance and create a hazardous situation. Do not use aerosol cleaners, they may be explosive and flammable under certain conditions.
- Always exercise care when moving or relocating equipment.
- Always locate the machine on a solid support surface that has adequate strength to support the weight of the machine.
- Always locate the machine in an area that has adequate ventilation and room for servicing.
- Always unplug this equipment from the electrical outlet before cleaning.

Note: Your Xerox® Machine is equipped with an energy saving device to conserve power when the machine is not in use. The machine may be left on continuously.

Do not do these:

- Never use a ground adapter plug to connect the equipment to a power outlet that lacks a ground connection terminal.

- Never attempt any maintenance function that is not specifically described in this documentation.
- Never remove covers or guards that are fastened with screws. There are no operator serviceable areas within these covers.
- Never locate the machine near a radiator or any other heat source.
- Never override or “cheat” any of the electrical or mechanical interlock devices.
- Never place this equipment where people might step on or trip on the power cord.



Caution: This device is not intended for use in the direct field of view at visual display workplaces.

To avoid incommoding reflections at visual display workplaces this device must not be placed in the direct field of view.

Electrical Information

WARNING - ELECTRICAL SAFETY INFORMATION

1. The power receptacle for the machine must meet the requirements stated on the data plate on the rear of the machine. If you are not sure that your electrical supply meets the requirements, please consult your local power company or an electrician for advice.
2. The socket outlet shall be installed near the equipment and shall be easily accessible.
3. Use the power cable that is supplied with your machine. Do not use an extension cord or remove or modify the power cord plug.
4. Plug the power cable directly into a correctly grounded electrical outlet. If you are not sure whether or not an outlet is correctly grounded, consult an electrician.
5. Do not use an adapter to connect any Xerox® Equipment to an electrical outlet that lacks a ground connection terminal.
6. Do not place this equipment where people might step or trip on the power cable.
7. Do not place objects on the power cable.
8. Do not override or disable electrical or mechanical interlock devices.
9. Do not push objects into slots or openings on the machine. Electrical shock or fire may result.

ELECTRICAL SUPPLY

- This product shall be operated from the type of electrical supply indicated on the product's data plate label. If you are not sure that your electrical supply meets the requirements, please consult your local power company for advice.



- Always connect equipment to a correctly grounded power outlet. If in doubt, have the outlet checked by a qualified electrician.



WARNING: This equipment must be connected to a protective earth circuit

This equipment is supplied with a plug that has a protective earth pin. This plug will only fit into an earthed electrical outlet. This is a safety feature. If you are unable to insert the plug into the outlet, contact your electrician to replace the outlet.

DISCONNECT DEVICE

The power cable is the disconnect device for this equipment. It is attached to the side of the machine as a plug-in device. To remove all electrical power from the equipment, disconnect the power cable(s) from the electrical outlet.

Emergency Power Off

If any of the following conditions occur, turn off the machine immediately and disconnect the power cable(s) from the electrical outlet(s).

- The equipment emits unusual odors or makes unusual noises.
- The power cable is damaged or frayed.
- A wall panel circuit breaker, fuse, or other safety device has been tripped.
- Liquid is spilled into the machine.
- The machine is exposed to water.
- Any part of the machine is damaged.

Maintenance Information

1. Any operator product maintenance procedures will be described in the user documentation supplied with the product.
2. Do not carry out any maintenance on this product which is not described in the customer documentation.
3. Do not use aerosol cleaners. The use of cleaners that are not approved may cause poor performance of the equipment, and could cause a dangerous condition.
4. Use supplies and cleaning materials only as directed in this manual.
5. Do not remove covers or guards that are fastened with screws. There are no parts behind these covers that you can maintain or service.
6. Do not perform any maintenance procedures unless you have been trained to do them by an authorized local dealer or unless a procedure is specifically described in the user manuals.

Product Safety Certification

This product is certified by the following Agency using the Safety standards listed:

Standard
UL60950-1 (USA)
CSA 22.2 No. 60950-1 (Canada)
IEC 60950-1, IEC 62368-1

Environmental Health and Safety Contacts

Contact Information

For more information on Environment, Health, and Safety in relation to this Xerox® Product and supplies, please contact the following customer help lines:

North America & Europe (Phone): 1-800-ASK-XEROX
North America & Europe (Fax): 1-585-422-8217

2. Welcome

Your new Xerox® Scanner can quickly scan stacks of single-sided or double-sided pages and place their electronic images on your computer.

What's in the Box

Before proceeding, check the contents of the box. If items are missing or damaged, contact the dealer where you purchased the scanner.



Xerox® D35 Scanner

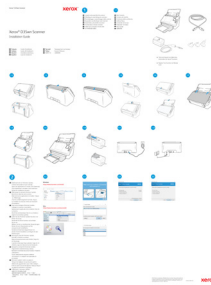

Installation Guide

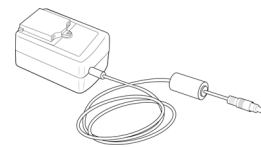

Power Supply

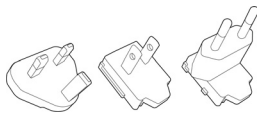

Plug Adapter

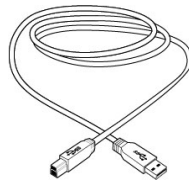

USB Cable

- Technical Support and Warranty Information
- Register Your Scanner and Review Card

System Requirements

PC Requirements

- Intel i3 or equivalent CPU
- Internet access (for installation)
- An available Universal Serial Bus (USB) port
- Microsoft® Windows® operating system:
 - 32-bit or 64-bit Windows 7 (Service Pack 1)
 - 32-bit or 64-bit Windows 8 / 8.1
 - 32-bit or 64-bit Windows 10

- Minimum of 2 gigabyte (GB) of internal memory (RAM)
- Minimum available hard disk space:
 - 350 MB for the scanner driver
 - 1 GB for Visioneer OneTouch
 - 1 to 3 GB for each additional application

A VGA OR SVGA MONITOR:

- The recommended settings for your monitor are:
 - Color quality of 16-bit or 32-bit
 - Resolution set to at least 800 x 600 pixels

Refer to your Windows documentation for instructions on setting the color quality and resolution for the monitor.

Documentation

The following printed documentation is provided in the box:

- **Installation guide**—abbreviated scanner setup and installation instructions.
- **Technical Support and Warranty Information**—contact information for technical support and customer service, and a brief overview of our standard product warranty.
- **Register Your Scanner and Review Card** — follow the instructions on the card to register your scanner. Please take a moment to write a short review of your experience with this scanner.

The following soft-copy documentation is available during installation or on

www.xeroxscanners.com:

- **Scanner user guide**—instructions for scanner setup, installation, operation, maintenance, safety, and warranty.
- **OneTouch scanning guide**—instructions for configuring and scanning using OneTouch.
- **TWAIN scanning guide**—instructions for accessing and scanning using the TWAIN interface.
- **Patch code sheets**—use with an application that supports detection of patch code data when using the TWAIN interface. The patch code page layouts have been specifically designed for your scanner. The file contains Patch 1, 2, 3, 4, T and 6 layouts for A4 and U.S. Letter size pages.

Xerox® D35 Scanner

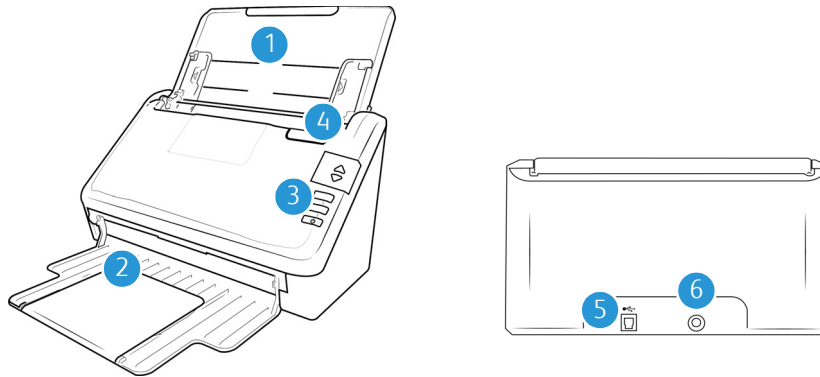

1. **Input tray**—Holds the documents in the Automatic Document Feeder for scanning.
 - **Extension**—Pull out to support various document lengths.
 - **Paper Guides**—Slide to adjust to document width.
2. **Exit tray**—Where the documents are exited out of the scanner. Flip up an exit stopper to keep documents in the exit tray. Exit extension pulls out to support various document lengths.
3. **Control panel**—Scanner hardware controls
 - **Status light/Power button**—Turns the scanner’s power on/off and indicates the scanner’s status.
 - **LED Number**—The selected OneTouch function for the Scan button.
 - **LCD Screen**—Shows the current scan settings or state of the scanner.
 - **Function buttons**—Selects the scan setting for the OneTouch buttons. Press the up or down arrow to cycle through the settings.
 - **Simplex button**—Press to scan single-sided documents.
 - **Duplex button**—Press to scan double-sided documents.
4. **ADF cover release**—Pull to open the Automatic Document Feeder.
5. **Universal Serial Bus (USB) port**—Connects the scanner to the computer.
6. **Power jack**—Connects the power supply to the scanner.

3. Scanner Setup

1. Remove the scanner from the shipping box, verify all parts listed on page 2-1 are in the box.
We recommend that you keep the original packing materials in case you need them later.
2. Remove any shipping tape from the scanner as indicated in the following illustration(s).

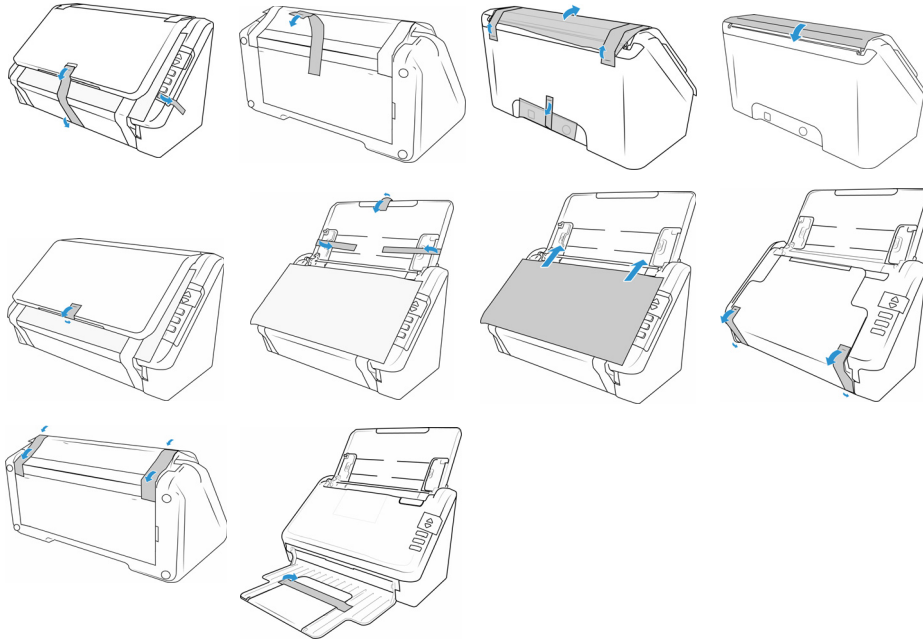

The illustrations are for example purposes only. Your scanner's packaging may vary slightly.

Connect the Scanner Power Supply

Note: Only use the power supply included with your scanner. Connecting any other type of power supply may damage your scanner, and will void its warranty.

1. Select the appropriate plug adapter for your country.

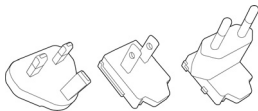

2. Slide the appropriate plug adapter to the power supply.

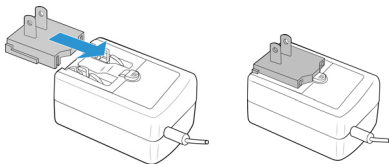

3. Plug the power supply into the power port on the scanner.

4. Plug the power supply into a wall outlet.

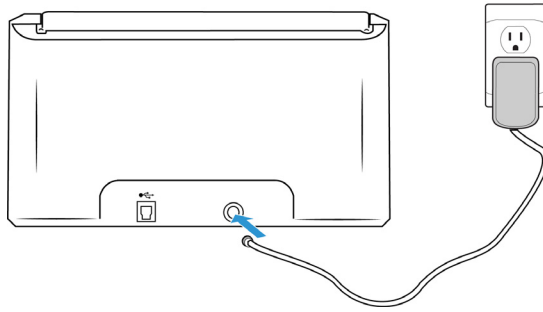

4. PC Installation

Please make sure of the following before you begin installation:

- If you are prompted to reboot during installation, please select No. Finish installing the rest of the software, then close all open windows and reboot your computer.
- The information in this guide may cover software not provided with the scanner you purchased. Please disregard any information about the software not applicable to your scanner.
- If your computer has antivirus or antispyware software running, you may encounter alerts or messages during installation asking you to allow the installation to proceed. Although the messages will differ based on the software your computer is running, in each case you should allow the installation to proceed if that option is available. Alternatively, you can turn off the antivirus or antispyware software before installing your scanner, but if you do, make sure to turn it back on again when installation is finished.
- If your computer is running Windows 7 or later, you may see the Windows User Account Control screen asking you to confirm system changes. Click the Yes. button to allow the installation to proceed.

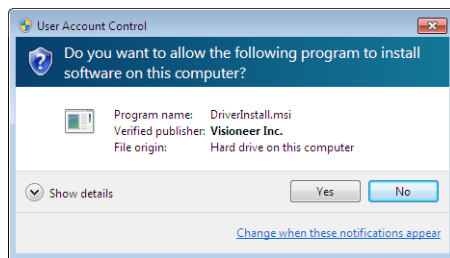

Install the Software and Connect the Scanner

1. Start Microsoft Windows and make sure that no other applications are running.
2. Go to www.visioneer.com/install.
3. Launch the installer, once the download is complete.
4. Plug the USB cable into the USB port on the scanner then into a USB port on the computer. Turn on the scanner power.

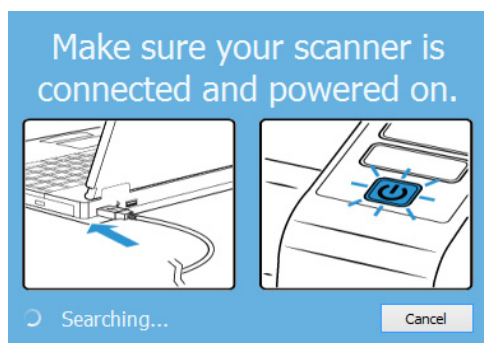

5. Click **OK**.

6. Select your scanner from the list.

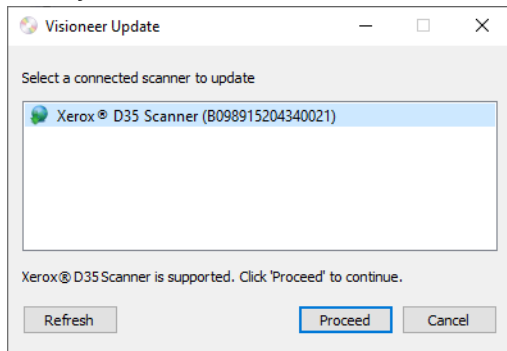

7. Click **Proceed**.
8. The Select Language window opens. Click the drop-down menu arrow and select the language to use. Click **OK**.

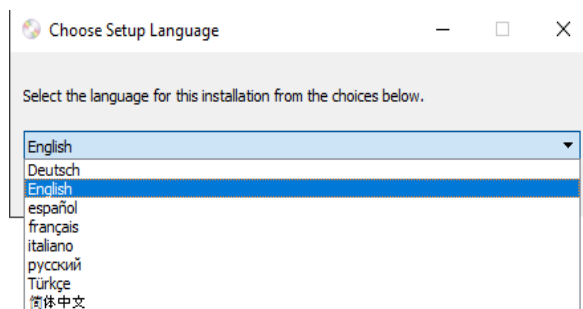

9. Make sure the boxes for **Scanner Driver** and **Visioneer OneTouch** are selected, as well as any other applications you want to install.

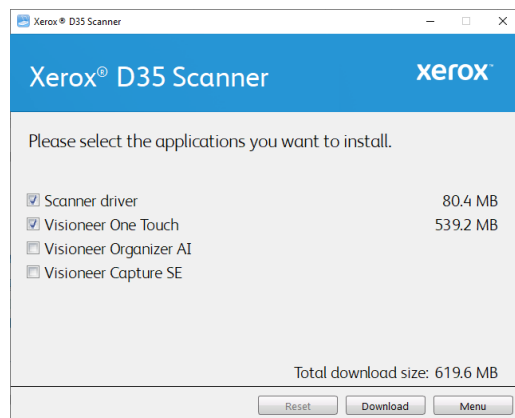

Note: The software provided with your scanner may differ slightly from the list shown in the window.

10. If a version of the software is already installed on the system, the option will be greyed out. However, if there is a newer version available, it will be possible to download and install
11. The software will have to first be downloaded by clicking **Download**. The total size of the download is shown at the bottom.

- After the download has begun, it can be paused. If changes to the selections are required, it is necessary to click **Reset** while the download is paused. This will allow the settings to be changed.

Note: Clicking the Reset button in either the Main menu or the Install menu will cause both partially completed and previously downloaded files to be deleted. In order to be installed they will have to be downloaded again.

- Once all software has been downloaded, click **Install**.

INSTALLING THE SCANNER DRIVER

The scanner driver installation will start first.

- The Welcome screen for the scanner driver Setup Wizard opens. Click **Next**.



- On the Xerox License Agreement window, read the license agreement. If you accept the terms, select **I Agree** then click **Next**.

If you choose not to accept the license agreement, click **Cancel**. Click **Close** on the Installation Interrupted window.

- The software will now be installed.
- Stop** when you see the “Complete the installation by connecting your hardware” window. Do not click **OK** yet. Leave the window open and proceed to the next section.

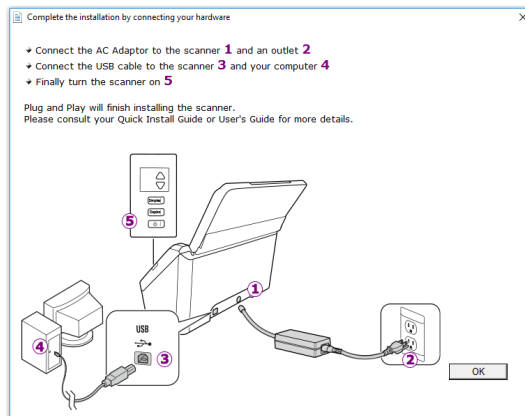

Note: If you do not see this on-screen diagram for connecting the scanner, stop and follow the instructions below.

CONNECT THE USB CABLE AND TURN ON THE POWER

If you did not connect the scanner earlier, proceed with the instructions below. It is recommended that the cable provided with the scanner is the one used.

1. Remove any tape from the USB cable.
2. Plug the USB cable into the USB port on the scanner then into a USB port on the computer. Check your computer's manual for USB port locations. If the plug does not attach easily, make sure that you are plugging it in correctly. Do not force the plug into either connection.

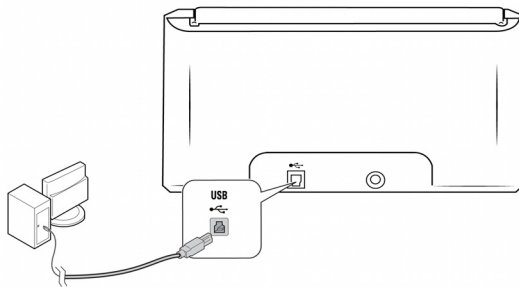

3. Press the power button to turn on the scanner.

The status light comes on and flashes indicating that the scanner is receiving power.

Your computer recognizes that a scanner has been plugged into the USB port and automatically loads the appropriate software to run the scanner.

4. When you're certain that the software has completely loaded, return to the "Complete the installation by connecting your hardware" window.

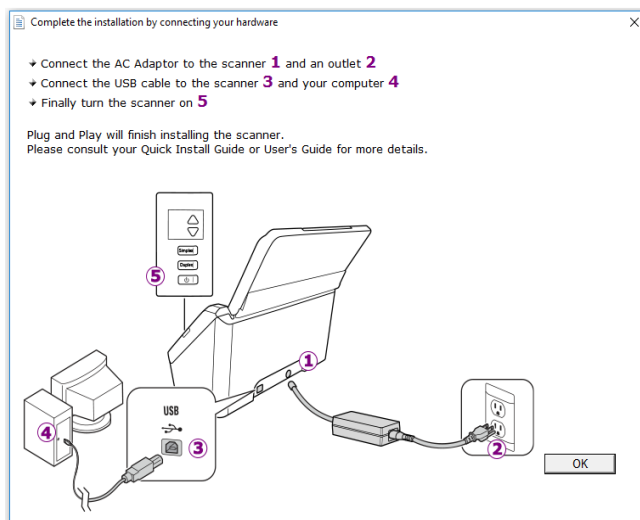

5. Click **OK** to complete the installation process.

- Click **Close** on the Installation Complete window to close and exit the driver installer.

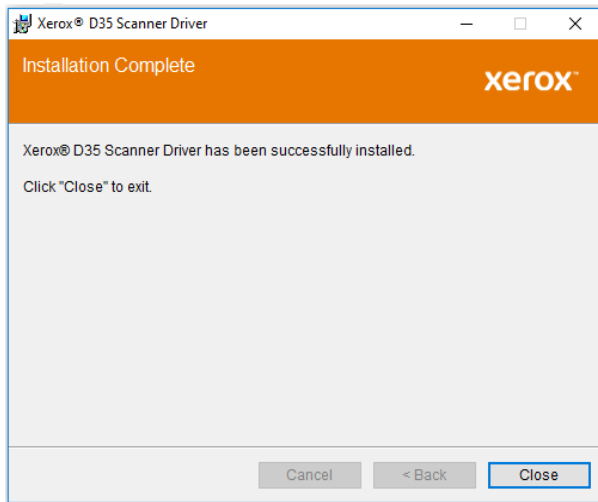

INSTALLING VISIONEER ONETOUCH

The Visioneer OneTouch software installation will start automatically after you click **Close** on the driver Installation Complete window.

- Click **Next** on the Welcome to the OneTouch Setup Wizard.



- On the Visioneer License Agreement window, read the license agreement. If you accept the terms, select **I Agree** then click **Next**.
If you choose not to accept the license agreement, the installation will terminate and OneTouch will not be installed.
- Click **Close** on the Installation Complete window to close and exit the software installer.

- After OneTouch installation is complete, the initial screen is displayed, and OneTouch initializes and searches for the installed scanner. Please wait until this screen disappears before trying to use OneTouch.



Note: If you selected other software to install during the installation, that software will automatically start after you click **Close** on the Installation Complete window. Follow the instructions on-screen to install each application you selected.

Installing Additional Applications

- Return to the Main menu and click Install software.
- If a version of the software is already installed on the system, the option will be greyed out. However, if there is a newer version available, it will be possible to download and install.
- The software will have to first be downloaded by clicking Download.
- Once all software has been downloaded, click Install.
- Follow the instructions on the screen to install each of the additional applications.

View the User Guides

- Launch Visioneer Update, go to the main menu and click on **View user guides**.

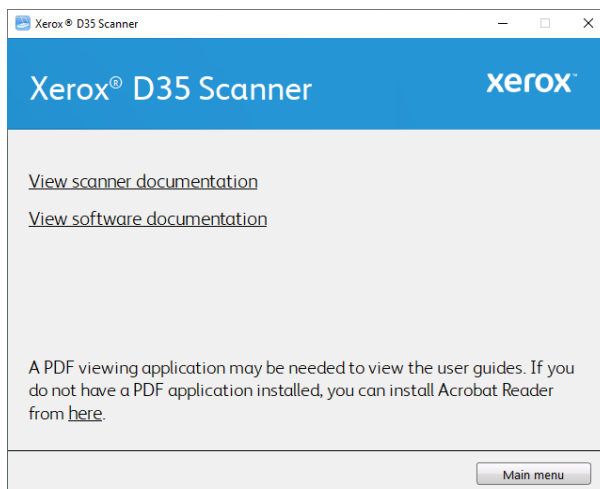

- Click on **View scanner documentation** to access the scanner user guide and scanning guides for OneTouch and TWAIN.

- **Scanner user guide**—Instructions for scanner setup, installation, operation, maintenance, safety, and warranty
- **OneTouch scanning guide**—Instructions for configuring and scanning using OneTouch
- **TWAIN scanning guide**—Instructions for accessing and scanning using the TWAIN interface

Click on **View software documentation** to access the user guides for the software applications provided with the scanner.

From either of these user guide windows, click on the **User guide menu** button to return to the main user guide window, then select the other documentation section to view the user guides.

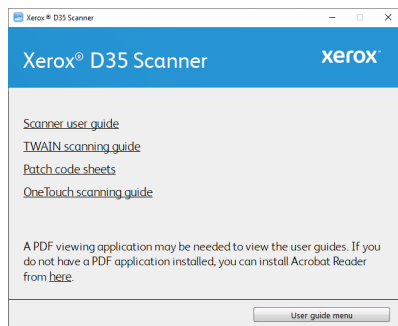

Scanner documentation window

3. Click the links of the guides you want to view.
4. When you're finished, click **Main menu** to return to the Main menu window and click **Exit**.

Register Your Scanner

Registering your scanner is important as it provides you with access to our free telephone support service. Registration also gives you free access to software updates for your scanner.

You will need an active network connection to register your scanner. If you do not have network access you can contact our customer service department to register the scanner. Please refer to the Technical Support Card, that you received with the scanner, for our customer service contact information.

1. Open an Internet Explorer window, or any other Internet browser you have installed on your computer.
2. Go to www.xeroxscanners.com.
3. Click on **Register Your Scanner**.
4. Fill in the registration form, all required fields have an asterisk (*).
A valid email address is required for registration.
5. You will be asked to enter the serial number for the scanner, it is located on the back or underside of the scanner.
6. After filling in the form, click on **Register** to complete the registration.

5. Loading Documents to Scan

Always remove any staples or paper clips from documents before inserting them into the scanner. Staples and paper clips can jam the feed mechanism and scratch the internal components. Also remove any labels, stickers, or Post-It™ notes that may come off during the scanning process and get stuck in the scanner. Misuse as described here will void your scanner's warranty. Please go to www.xeroxscanners.com, select your product, and then click the "Warranty" link to view the warranty terms and conditions for your scanner.

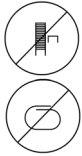

Supported Document Types

You can scan the following types of documents with this scanner.

- Maximum amount of paper in the input tray
 - Approximately 50 pages of 20 lbs (80 g/m²) new printer paper
- Document size
 - Minimum size (width x length) – 2.9 x 2.0 inches (74 x 52 mm)
 - Maximum size (width x length) – 8.5 x 14.0 inches (216 x 356 mm)
 - Maximum length with long document enabled
 - at 300 dpi: 218.0 inches (5540 mm)
 - at 600 dpi: 59.0 inches (1499 mm)

We recommend scanning one page at a time when the documents you are scanning are longer than 14 inches (356 mm).

- Mixed document stacks
 - Scanner minimum to maximum without long document enabled

Arrange the documents so that all items are centered in the stack. The document sensor, paper separation, and feed rollers are located in the middle of the paper path. If smaller items are offset from the center they will not be detected. This will cause feeding issues and paper jams. The ratio between the smallest and largest page in the stack should be no more than 1.5.
- Page thickness
 - Minimum: 50 g/m² (13 lbs)
 - Maximum: 413 g/m² (110 lbs)
- Plastic Cards thickness
 - Maximum: 413 g/m² (110 lbs)
- Embossed Plastic Cards thickness

- 1.25 mm

Documents to Avoid Scanning

The documents in this list can be scanned, but please note that scanning documents of this type will reduce the life of the scanner. Maintenance will be required more often and replaceable parts will wear faster. These types of documents will jam more frequently and damage to the original documents may occur. If you do choose to scan these document types, do not scan large batches. This type of use is not covered under the scanner warranty and alters replacement parts life expectancy.

We recommend you limit the amount or completely avoid scanning documents that are in this list.

- Curled, wrinkled or folded documents may cause paper jams or multiple pages being fed through the scanner at one time.
- Perforated or punched paper that could tear when the separation roller engages.
- Coated paper or photographs where the coating can flake off during scanning and leave residue in the scanner.
- Extremely smooth, shiny, or highly textured paper may cause the paper feed rollers to slip across the page and cause the scanner to report a paper jam.
- Carbonless copy paper may tear while being fed through the scanner and the pressure of the rollers may leave streaks on the page. The chemical coating on this paper will rub off on the rollers during the scan process, increasing the frequency of miss-feeds and paper jams.
- Partially transparent paper such as tracing paper as any images from the opposite side of the page or black background will appear in the scanned images.

Unsupported Document Types

Do not scan the following types of documents as they may cause damage to the scanner.

- Items outside of the specified supported sizes, thickness, and weight defined in this document.
- Non-rectangular or irregularly shaped paper will cause the scanner to detect and report document skew errors or paper jams.
- Carbon paper that will leave residue in the scanner and on the rollers that will transfer to the next set of documents scanned.
- Documents with hard items attached such as paper clips, binder clips, and staples.
- Documents with wet ink or white-out.
- Thermal or photosensitive paper.
- Overhead projector sheets, plastic film, camera film, and any other type of transparent or partially transparent plastic item.
- Documents that have been glued together.
- Cloth or metallic sheets.

Scanning from the Automatic Document Feeder (ADF)

PREPARING DOCUMENTS FOR SCANNING

- Fan the documents to make sure all pages in the stack are separated.
- Bend and then flatten the document stack to make sure the horizontal edges are aligned to help prevent paper from skewing while being pulled through the scanner.
- Pinch the ends to align the leading edges slantwise to help prevent multiple pages from being fed through at a single time.

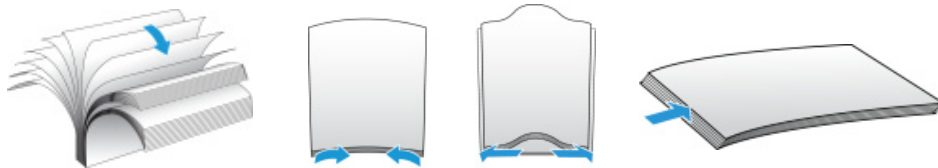

LOADING DOCUMENTS

1. Adjust the paper guides to the width of the document you want to scan. Extend the input tray and output tray to the length of the document.



2. Load the documents *face down* with their tops into the Automatic Document Feeder.

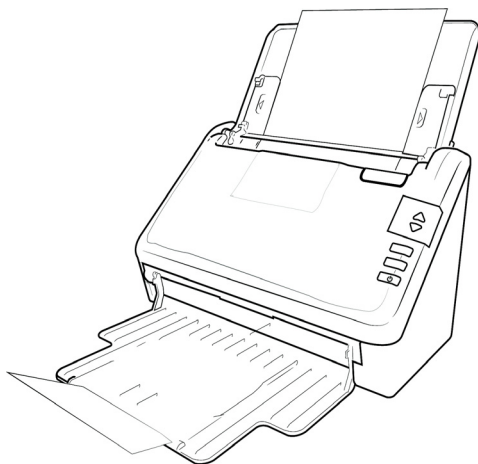

3. You can now scan the documents using the scanner button, OneTouch, or one of the other scanning interfaces.

Scanning Interfaces

- **Scanner Control Panel**—When you press the Simplex or Duplex button on the scanner, the scanner starts scanning using the settings for the current LED number. The scanned image is then sent to a destination on your computer or network drive.
- **OneTouch Button Panel**—Use this scan option when you want to scan from the computer screen. Scanning from the on-screen OneTouch Button Panel is the same as selecting a scanning option on the scanner, except you click an icon that represents the function

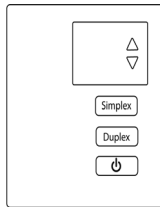

Scanner Control Panel

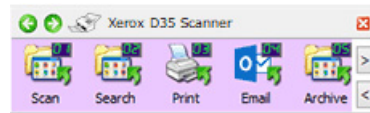

OneTouch Button Panel

Please see the OneTouch Scanning Guide, available online, for instructions. You can also click the **Help** button in the OneTouch Properties window to open the instructions in an Internet browser.

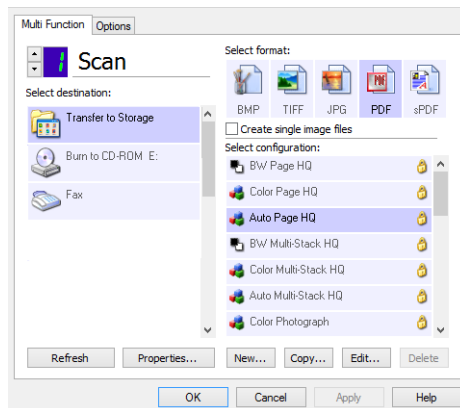

- **TWAIN and WIA Interface**—This option uses your scanner’s TWAIN interface to scan. Select scanning options before scanning, put the document in the scanner, then click the **Scan** button in the TWAIN interface window.

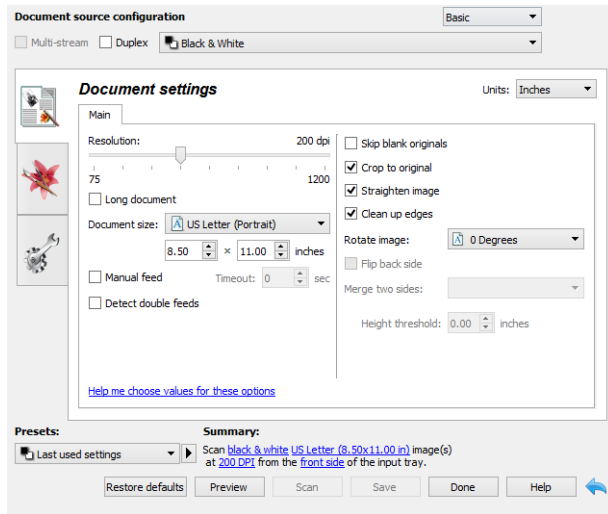

Please see the TWAIN Scanning Guide, available online, for instructions. You can also click the **Help** button in the TWAIN interface to open the instructions in an Internet browser.

6. Scanner Options, Maintenance and Troubleshooting

This section contains information on hardware options available for your scanner, maintenance instructions, troubleshooting, uninstalling, scanner specifications, and spare parts.

Safety Precautions

When servicing the scanner you should take the following precautions to ensure your safety and prevent damage to the scanner.

Do These

- Wear protective gloves when cleaning the scanner with isopropyl rubbing alcohol. Rubbing alcohol may irritate sensitive skin.
- Only perform scanner maintenance as described in this chapter.
- Keep the scanner and cleaning supplies away from any open flame or heat source as any form of alcohol is flammable.
- Always read the instructions in each section carefully, the instructions are specific to the part you are installing or servicing.
- Move the scanner to an area that has adequate room for opening the scanner.
- If your scanner has a power supply, always turn off the scanner and unplug the power supply before performing maintenance, unless the maintenance instructions below specifically state to leave the scanner plugged in and powered on.
- Always unplug the USB cable from the scanner before performing maintenance, unless the maintenance instructions below specifically state to leave the scanner plugged in.
- Wear an anti-static strap to prevent electrostatic discharge when touching metal components.
- Keep all cleaning supplies, scanner parts and accessories out of the reach of children.

Do Not Do These

- Never attempt installation of any part not described in this manual.
- Never service the scanner near a radiator or any other heat source.
- Never use aerosol sprays or compressed air, or attempt to lubricate parts with an oil or silicon spray.
- Never service the scanner in an area where there are open liquid containers.
- Never pour or spill liquid on the scanner or any of its components.

Hardware Properties

You can use the scanner's properties page to keep track of scanner maintenance, change some of the hardware options, configure the scanner interface behavior, and adjust application options that may be available for your scanner.

To open the scanner hardware properties page:

- **Windows 7** and later—from the Windows Control Panel, open **Hardware and Sound** and then **Devices and Printers**.

Right-click on the scanner and then select **Scan properties** from the list. Click **Yes** if you are prompted by the Windows User Account Control to confirm that you want make changes to the system settings.

DEVICE SETTINGS

The Device Settings tab shows the hardware information for your scanner. The options on the Device Settings tab will be available based on whether or not the scanner hardware supports the feature. Some features described herein may not be available for the current scanner. Please disregard any information about features that you do not see in the interface for your scanner.

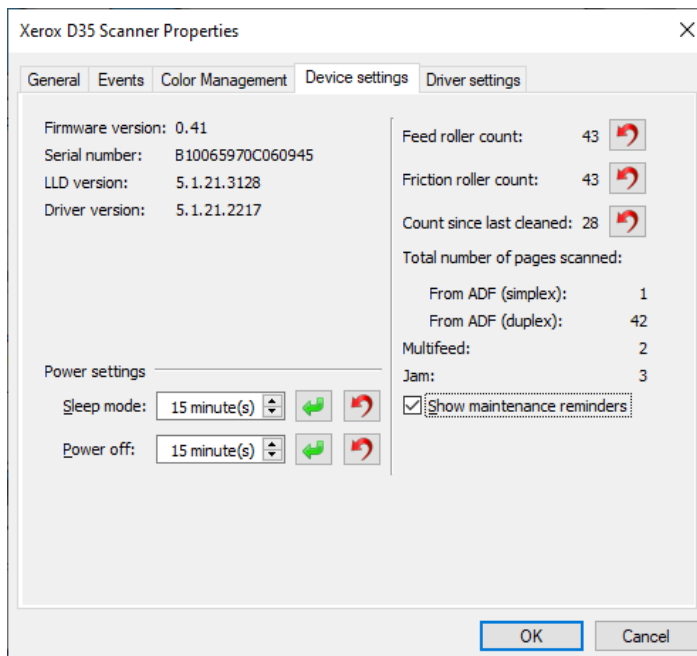

Scanner Details

- **Firmware version**—this is the scanner’s hardware processor version number.
- **Serial number**—the scanner’s unique identification number.
- **LLD version**—the scanner’s base driver version. This is not the OneTouch software revision, TWAIN or WIA driver versions.
- **Driver version**—this is the version of the scanner’s TWAIN driver.

Power Settings

Some features described herein may not be available for the current scanner.

- **Sleep mode**—sleep mode is the low-power state when the scanner is not in use. You can adjust the amount of time you want the scanner to wait before it goes into low power.

Click the green enter button to save any changes in the Sleep mode field.

Click the red reset button to reset to the default timeout value.

- **Power off**—input the number of minutes you want the scanner to wait before it turns itself off.

Click the green enter button to save any changes in the power off field.

Click the red reset button to reset to the default timeout value.

Scanner maintenance:

- **Counters**—click the reset button next to the counter you want to set back to 0.
- **Show maintenance reminders**—select this option be notified when it is time to clean or replace the rollers. After cleaning or replacing the rollers, click the reset button next to the roller counters in this screen.

DRIVER SETTINGS

The options in this panel are for configuring how the TWAIN interface will behave in some scenarios. Please see the TWAIN scanning guide for instructions.

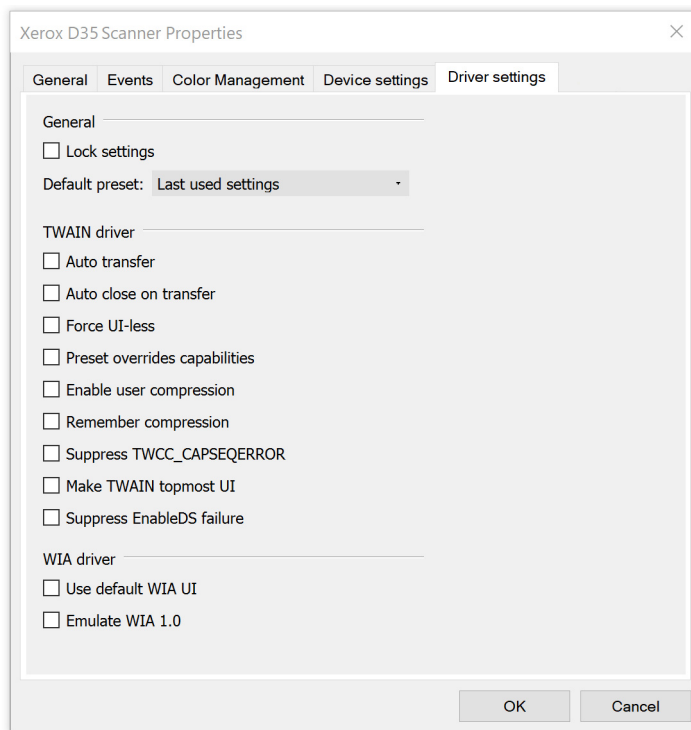

Clearing Paper Jams

If your scanner stops scanning due to a paper jam in the Automatic Document Feeder, use the following procedure to remove the paper from the scanner.

1. Pull on the scanner cover release and lift the lid to open the scanner.
Do not attempt to remove a jammed page with the ADF door closed.

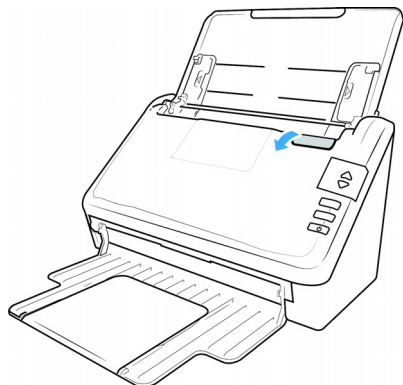

2. Remove the jammed page from the scanner.
3. Close the ADF door and continue scanning.

To reduce the number of paper jams, smooth and straighten the paper before scanning and adjust the paper guides to the paper size.

Cleaning the Scanner

Regular maintenance of your scanner can help to ensure continual optimal performance.

Using a soft, lint-free cloth, wipe down all plastic surfaces on the scanner.

CLEANING THE OUTSIDE OF THE SCANNER

Excessive dust accumulation around and on the scanner will pull into the scanner during the scanning process and clog the ventilation openings. You should clean the outside of the scanner at least once a month to help limit the amount of dust build up in the scanner.

1. Turn off the scanner power.
2. Using a soft dusting cloth, wipe down the body of the scanner, input tray and exit area. Make sure that the input and exit slots in the scanner are also clean.
3. When you're finished, press the power button to turn the scanner back on.

CLEANING THE INSIDE OF THE SCANNER

Cleaning the inside of the scanner helps to keep your scanner operating at optimum performance. You should clean the inside of the scanner at least once a week or after 20,000 pages have been scanned. If you are getting frequent paper jams, multiple pages feeding at the same time, or you're seeing lines in the scanned image, it is time to clean the scanner.

Note: When cleaning the rollers, do not rub the roller cleaning paper vigorously back and forth across the roller, this will shred the roller cleaning paper and leave debris in the scanner.

Safety Precautions

- Keep the roller cleaning paper away from fire, heaters or any open flame or heat source as any form of alcohol is flammable.

- Wear protective gloves as the roller cleaning paper may irritate sensitive skin.
- Only clean the rollers and scanning areas, as described in this section, with the roller cleaning paper.
- Do not leave the roller cleaning paper or any of the cleaning supplies where children can access them.
- Always turn off the scanner and unplug the scanner's power and USB cable prior to using the roller cleaning paper.

Preparation

- Roller cleaning papers can be purchased from our website at www.xeroxscanners.com in the Supplies & Accessories page for your scanner.
- When cleaning the inside of the scanner, you should clean all of the rollers, scanner glass and background plates at the same time.
- Use scissors to open the roller cleaning paper bag, cutting across the dotted line.

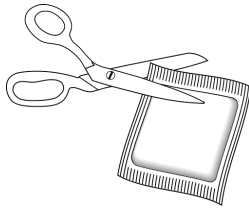

! **Caution: The roller cleaning paper is moistened with isopropyl rubbing alcohol. Please read and follow these precautions to ensure your safety.**

CLEANING THE ADF ROLLERS

When you perform cleaning for the feeding rollers in the lower part of the scanner, the rollers need to be rotated with a light force.

1. Pull on the scanner cover release and lift the lid to open the scanner.

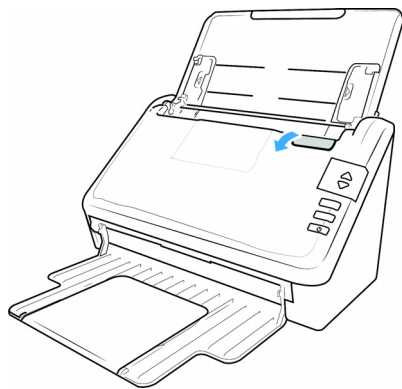

2. The following illustration shows where the rollers are located in the scanner.

Use a roller cleaning paper, or the wet soft cloth with isopropyl rubbing alcohol (70%), to clean all of the rollers indicated in the illustration.

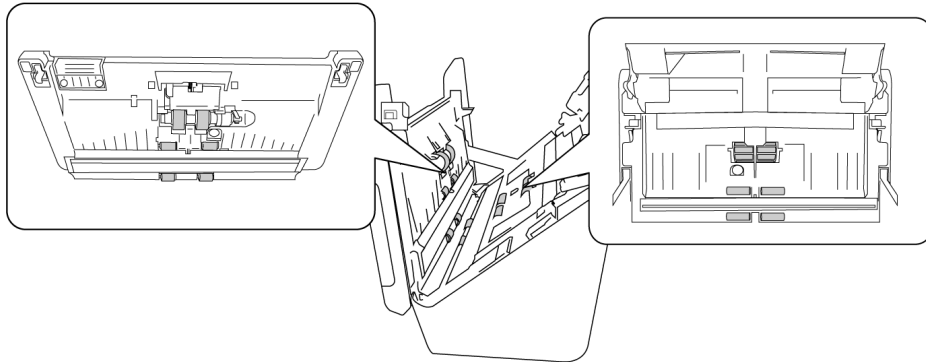

Note: Be careful when cleaning the rollers. All of the rollers, except the free rollers, are designed to rotate in one direction only. Do NOT force the roller to rotate in the opposite direction. Forcing the roller to rotate will damage it, and cause the scanner to feed pages incorrectly.

CLEANING THE SCANNER GLASS AND BACKGROUND PLATES

The background plates are located underneath the scanner glass in both the top and bottom of the scanner. If you see a warning message that one of the background plates is dirty, simply clean the scanner glass as described here.

1. Pull on the scanner cover release and lift the lid to open the scanner.

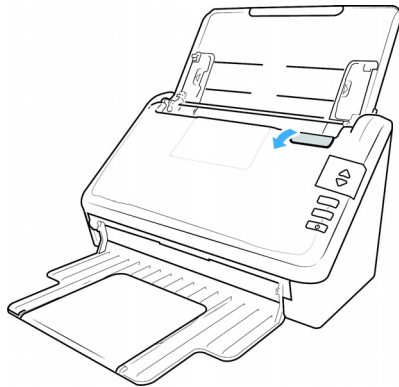

2. The following illustration shows the location of the glass in the scanner.

Use a soft cloth to wipe clean the glass. You can use a roller cleaning paper to clean the glass plates if there is any sticky residue on the surface.

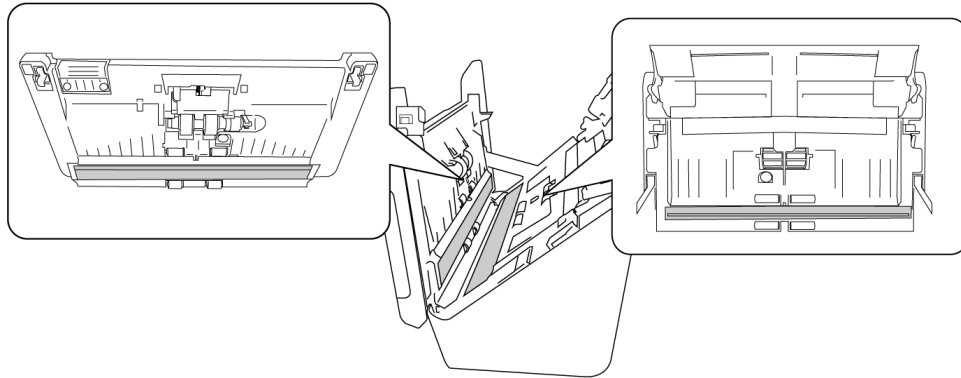

CLEANING THE PAPER SENSORS

The scanner has several sensors to detect the status of the paper when it is in the scanner. You should clean these sensors as part of your standard weekly maintenance of the scanner.

Note: Do not clean the sensors with the roller cleaning paper.

Preparation

- Turn off the scanner prior to cleaning the sensors.

CLEANING THE ADF SENSORS

1. Pull on the scanner cover release and lift the lid to open the scanner.

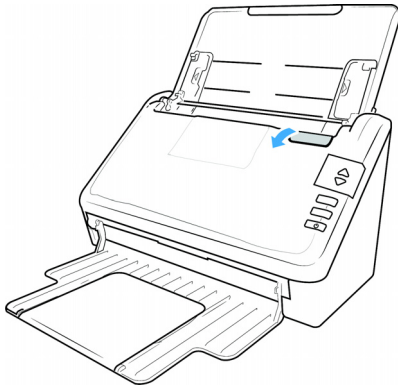

2. The following illustration shows the location of the sensors in the scanner.

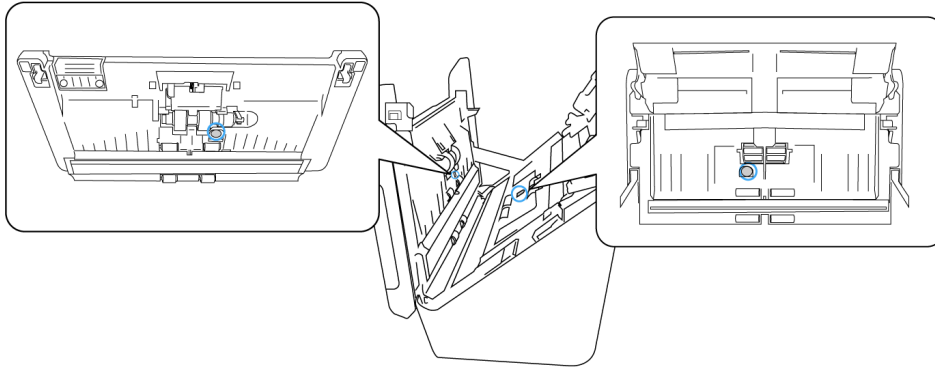

3. Using a clean, dry cotton swab, brush away any dust on the double feed detection sensors.

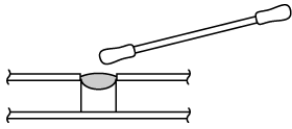

Replacing the Rollers

When replacing the rollers described in this section, you should replace all of the rollers at the same time. Do not replace just one roller and not the other. When you are finished replacing the roller, reset the roller count as described in the page 6-2.

⚠ WARNING: Keep all replaceable parts out of the reach of children. These parts are small and pose a choking hazard.

Turn off the scanner power then unplug the power supply from the scanner. Pull the cover release handle and open the scanner.

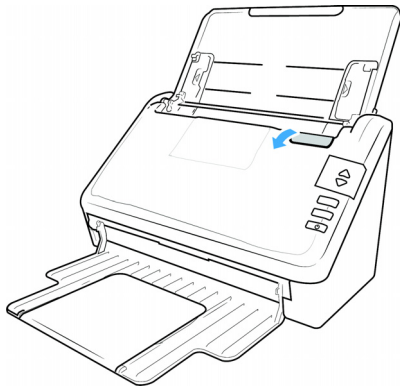

When you are done replacing the rollers, close the scanner carefully pressing down on both sides of the cover until it locks in place. Do not slam down the cover.

REPLACING THE FEED ROLLER

1. Pull on the scanner cover release and lift the lid to open the scanner.

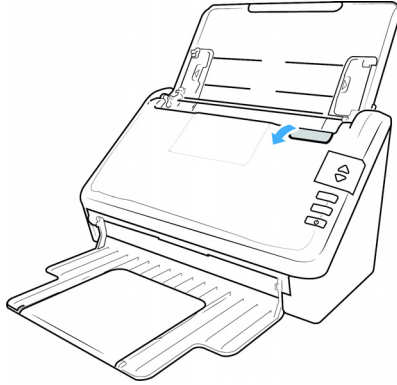

2. Locate the roller cover in the body of the scanner.

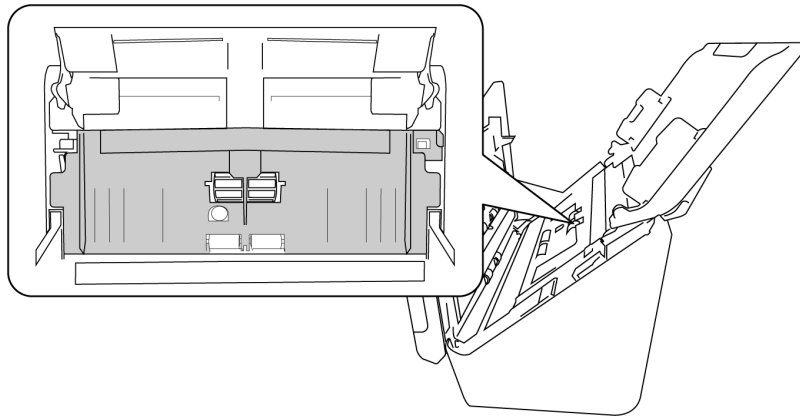

3. Pull down the paper feed roller cover, using the tab indicated in the illustration below, and gently pull it towards you holding both sides of the cover door, to access the roller.

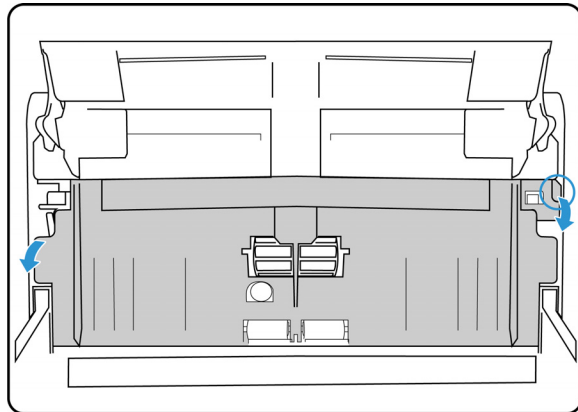

4. Pull up on the plastic arm holding the roller in place.

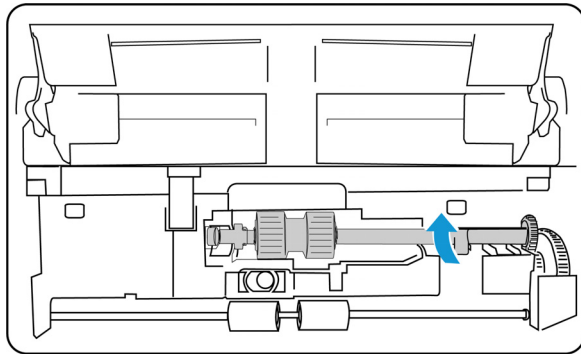

5. Detach the right end of the paper feed roller from the scanner and remove the feed roller.
6. Discard the roller, it cannot be repaired or reused.
7. Take the new roller out of its packaging.



8. Align the end of the bar with the hole at the left. Push the plastic arm down to hold the roller in place.

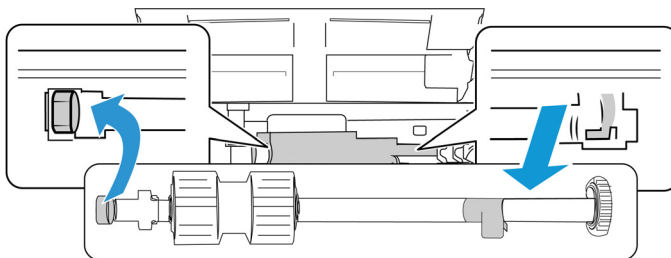

9. Lift the roller cover up and carefully push it closed to lock it in place. Make sure everything is aligned properly and the cover is fully closed. If the cover is not fully closed it will break during scanning and damage the scanner

REPLACING THE FRICTION ROLLER

1. Pull on the scanner cover release and lift the lid to open the scanner.

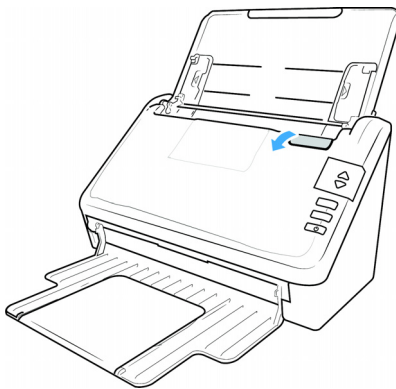

2. Locate the friction roller cover in the body of the scanner.

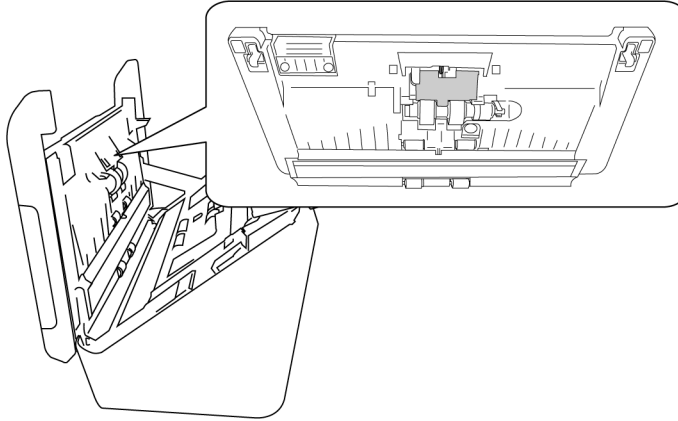

3. Use the little tab to flip open the friction roller cover.

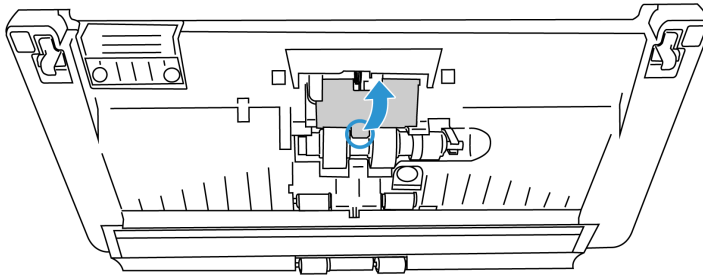

4. Pull out the friction roller gently from the right side.

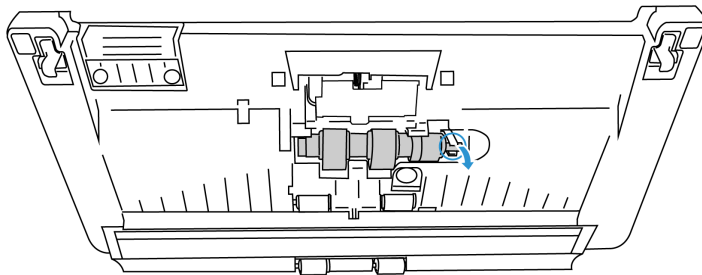

5. Discard the roller, it cannot be repaired or reused.

Note: Do **not** discard the bar.



6. Take the new roller out of its packaging.

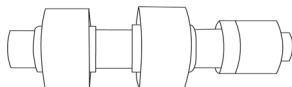

- Slide the friction roller on the bar. Insert the friction roller left side first until it's properly inserted in the slot. Make sure the left side of the bar is facing up.

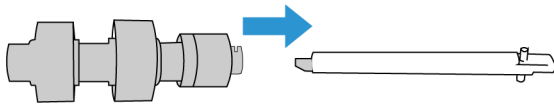

- Push the left side, then the right side of the roller into place.
- Close the friction roller cover when you are finished.

ERROR LIGHT TROUBLESHOOTING CODES

Normal Operation

- Steady blue: indicates the scanner is ready to scan.
- Slow flashing blue: indicates the scanner is in low power mode.
- Rapid flashing blue: indicates the scanner is waking up from low power mode.
- Steady red: the scanner is busy.
- Flashing red: the scanner is reporting an error.

Error Codes

The status light indicates the current state of the scanner. If your scanner experiences hardware problems, the status light turns red and will flash a specific number of times, pause, and then repeat the same number of flashes. The number of flashes between pauses indicates the hardware error code. The LED display will also flash an "E" then the error code number that matches the status light's blinking pattern.

Descriptions of the most common patterns are listed below. In all cases, you should turn off the scanner and check the scanner setup. Make sure the USB cable is plugged into the scanner and computer. Make sure the power cord is plugged into the scanner and into a wall outlet. Contact Xerox Technical Support if you experience a different blinking pattern.

Error Code	Problem Description	Solution
0	Scanner is not connected to the computer (The LED does not flash "E" and the status light remains blue.)	A cable may be loose. Check that the scanner's cables are correctly attached to the computer. If the scanner still does not connect, reboot the computer.
3	The scanner was locked when you tried to scan.	Turn off the scanner, slide the locking tab to the unlocked position, then turn the scanner back on. If the problem persists, reboot your computer.
4	Paper jam	Open the ADF cover and remove the jammed page. See Clearing Paper Jams on page 6-3.

Error Code	Problem Description	Solution
6	The scanner's cover is open	The ADF door is not closed all the way. Open the scanner then close it again. Push down on the lid until it locks into place.
1,2,7 or 8	The lamp in the scanner body or lid has malfunctioned	This usually occurs if the power was disconnected during a scan. Turn the scanner off, then back on again. If the problem persists, turn off the scanner, re-start the computer, then turn the scanner on. If the problem continues, and your scanner's power is plugged into a surge protector or UPS battery backup, try plugging the scanner power directly into a wall outlet.
All Other Codes	An internal part in the scanner may have malfunctioned	Turn off the power to your scanner, then turn it back on. If the problem persists, re-boot your computer. If the problem still persists, contact Xerox Technical Support.

Troubleshooting

Problem: The scanner won't scan. What's wrong?

Check for one of these possible causes:

- **Are the cables loose or not plugged in securely?** Inspect the cable connections. Make sure the cables are plugged in securely.
- **Is the scanner's status light on?** Turn on the scanner's power. If the status light doesn't come on, plug the power supply into another electrical outlet. If you are using a UPS battery back-up or power strip, try plugging the scanner directly to a wall outlet.
- **Did you restart the computer and scanner?** If the scanner gets a paper jam, or loses connection because of an error, try restarting your computer and power cycling the scanner.
- **Did you plug the scanner into a USB hub?** If you're using a USB hub to connect the scanner try plugging the scanner's USB cable directly to the back of the computer. It is not recommended that you use the scanner with a USB hub, if you are using a hub, the hub must have its own power supply.
- **Is the USB cable 6' or less?** If you are using a USB cable that is longer than 6' you may lose connection to the scanner. The recommended USB cable length is 6' or less, the USB cable provided with your scanner is within this range.
- **Did you select another image source in the scanning software?** If you use multiple imaging devices with your computer, such as a camera, all-in-one printer, or another scanner, you may have selected another source for images. Make sure Xerox® D35 Scanner is selected as the scanner.

Problem: The scanned images are of poor quality. What do I do?

There are various reasons why the scanned image is of poor quality. The original document may not be of good quality or the scanner glass may be dirty.

- Try cleaning the scanner. The scanner glass is where the image is captured as the page is pulled through the scanner. Lift up on the exit release, under the input tray, to open the scanner. There is glass in the body of the scanner and underneath the lid. Take a soft cloth and wipe across both pieces of glass. The section [Cleaning the Scanner Glass and Background Plates](#) contains thorough instructions for cleaning this part of the scanner.

Problem: Why does my scanner not function after performing a system restore on Windows?

The system restore process may have corrupted some of the driver components. It is recommended that you reinstall your scanner driver. Please refer to [Uninstalling Your Scanner](#) for installation instructions.

Problem: Why won't my scanner buttons work after scanning with Windows Image Acquisition (WIA)?

After performing a scan using the WIA interface you must close the application you were using before scanning with the buttons on the scanner. This does not occur when scanning using the TWAIN interface.

Problem: Why won't my scanner work after the computer has been sitting idle for several hours?

To resolve the problem, simply turn off the scanner power then turn it back on again.

This may occur after Windows goes into power saving mode to "hibernate" the computer into a low power state. When you move your mouse or type on the keyboard it "wakes" the computer back up and restores full power to the system. This power fluctuation during the computer's hibernating period may sometimes cause the scanner to lose communication to the computer.

Problem: The installation will not complete successfully. If installation finishes, the scanner's OneTouch options do not seem to work properly.

A likely cause is that some driver programs are already installed on your computer for another scanner. They may be interfering with the installation and OneTouch options, and you need to remove those other drivers and re-install your Xerox® Scanner. You can remove these programs from the Windows Control Panel. Please refer to the user manual provided with your other scanner hardware for instructions about removing the driver and software for that unit.

Problem: My computer keeps giving me out of hard drive space error messages.

The minimum requirement of free hard drive space is for the installation of the scanner driver and basic, low resolution, scanning. High resolution scans result in files that can be over 1 gigabyte in size. Free up some space on your hard drive for the software to be able to save the scanned images.

Problem: The paper jams the ADF.

To reduce the number of paper jams, smooth and straighten the paper before scanning, and adjust the guides to the paper size. Paper fed into the ADF at an angle can cause the feed mechanism to jam. If paper jams are occurring more frequently, try cleaning the roller with a soft cloth dampened with isopropyl rubbing alcohol. Excessive dust on the roller can make it appear worn and will cause issues feeding paper. See [Cleaning the Inside of the Scanner](#) for cleaning instructions.

Problem: The ADF won't feed pages properly.

A dirty or worn roller can cause documents to feed in skewed at an angle, or multiple pages to feed at the same time. First, try cleaning the rollers as described in [Cleaning the Inside of the Scanner](#). If the problem persists, the separation and/or feed rollers may need to be replaced. Please see [Replacing the Rollers](#).

Problem: If the USB cable is disconnected during a scan, the scanner does not reconnect when the USB cable is plugged back in.

Unplug the power supply from the scanner, and then plug it back in.

If the scanner does not reconnect:

1. Unplug the power supply from the scanner.
2. Restart your computer.
3. After the restart is complete, plug the power supply back in.

Problem: The scanner reports a Double Feed error when there is only one page in the scanner.

Try cleaning the double feed detection sensor. Dust on the sensor may prevent the sensor from working properly.

Uninstalling Your Scanner

Use the options in the Windows Control Panel to remove the scanner driver and modules, and any other software provided with the scanner.

Please leave the scanner's USB cable plugged into the computer while uninstalling the scanner driver. Unplug the USB cable when directed to do so in the instructions below.

Open the list of installed programs in the Windows Control panel.

- Windows 7 and later: Open Programs and Features

Uninstalling the scanner driver:

1. In the list of installed programs click Xerox® D35 Scanner driver.
2. Click the **Change** or **Uninstall** button.
3. Click **Yes** when asked to confirm that you want to remove the driver.

When the driver uninstallation is complete the progress window will automatically close.

4. Turn off the scanner and unplug the USB cable.

5. Reboot the computer if you are prompted to do so.

Follow these instructions to remove any of the other software you installed with your scanner. Depending on the software provided with your scanner, and which applications you installed during the scanner setup, the application list may include:

- OneTouch
- OneTouch OCR module
- Visioneer Organizer AI
- Visioneer Capture SE

Uninstalling Visioneer Acuity™:

Visioneer Acuity is automatically installed when you install the scanner driver. You can also download the Visioneer Acuity module from the support pages for your scanner at www.xeroxscanners.com. Visioneer Acuity is a utility with advanced image processing options to instantly improve the visual clarity of anything you scan.

1. In the list of installed programs select **Visioneer Acuity Assets**.
2. Click **Yes** when asked to confirm you want to remove the software.





Depending on the method of installation, and your scanner model, there may be multiple entries for Visioneer Acuity in the installed programs list. The additional entries in this list are the image processing libraries needed to support various scanner models. These additional items will be called “Visioneer Acuity Assets” followed by a version number. In the scenario described here, when you want to uninstall Visioneer Acuity make sure you select and uninstall Visioneer Acuity. If you uninstall one of the entries labeled as an “asset” you will still need to uninstall the main Visioneer Acuity utility.

Xerox® D35 Scanner Specifications

Scanner Specifications	
Document Requirements	
Minimum Item Size	2.9 x 2.0 inches (74 x 52 mm)
Maximum Item Size	8.5 x 14.0 inches (216 x 356 mm)
Capacity	50 pages of 20lb printer paper (80 g/m ²)
Paper Thickness	50 ~413 g/m ² (12 ~ 110 lbs)
Maximum Embossed Card Thickness	1.25 mm
General Specifications	
Scanning Speeds	45 pages per minute / 90 images per minute @ 200 dpi
Optical Resolution	600 dpi
Supported Resolutions	100, 150, 200, 300, 400, 500, 600 dpi
Interpolated Resolutions (Visioneer Acuity)	75 and 1200 dpi (these resolutions are available when Visioneer Acuity is installed)
Output Bit Depth	24-bit color, 8-bit grayscale, 1-bit bitonal (black & white)
Scan Method	Duplex Automatic Document Feeder (ADF)

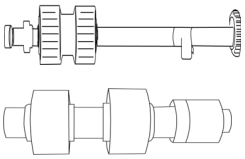
Scanner Specifications	
Image Sensor	CIS (Contact Image Sensor)
Light Source	RGB LED
Interface	USB 2.0 Port (USB 1.1 compatible)
Certifications	ENERGY STAR 3, USB 3.1 Gen 1, RoHS, CE, CB, WEEE, UL, C-UL, EPEAT (Gold), FCC Class B, UKCA
Operating Temperature	41° to 95° F (5° C ~ 35° C)
Relative Humidity	15% ~ 85% RPH
Scanner Dimensions	
Width	11.2 inches (285 mm)
Depth	18.5 inches (470 mm)
Height	12.8 inches (325 mm)
Weight	5.1 lbs (2.3 kg)
Power Information	
Power Supply	100~240Vac
Power consumption	≤ 20 Watts (during operation) ≤ 8.6 Watts (ready) ≤ 1.8 Watts (sleep mode after 15 minutes without scanning) ≤ 0.28 Watt (power off)
Cable Information	
Plug	US— 2P,90°, APD-US, APD, FOR WA-36A24R0,0~40°C, RoHS EUR(CEE)— 2P, 90°, APD-EU, APD, FOR WA-36A24R0, 0~40°C, RoHS UK(BS/PSB)— 3P, 90°, APD-GB, APD, FOR WA-36A24R0, 0~40°C, RoHS
USB Cable	2.0 USB, 1850 mm, 28AWG, RoHS Compliant
Software Information	
Supported Operating Systems	Microsoft Windows – 32-bit or 64-bit, 10 – 32-bit or 64-bit 7 (Service Pack 1) – 32-bit or 64-bit 8 / 8.1
Scanner Drivers	TWAIN, WIA
Bundled Software	Visioneer OneTouch® Visioneer Acuity Module Visioneer Organizer AI Visioneer Capture SE

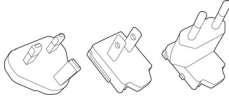
Xerox® D35 Scanner Parts List

Part Name	Part Number	
Cleaning and Maintenance Kit	96-X333-000	
• Feed (ADF) Roller	65-3212-000	
• Friction Roller	65-3213-000	
USB Cable	35-0118-000	
Plug	(US) 35-0266-000 (EUR) 35-0267-000 (UK) 35-0268-000	
Power Supply	37-0105-000	

7. Appendix A: Regulatory Information

Basic Regulations

UNITED STATES (FCC REGULATIONS)



This equipment has been tested and found to comply with the limits for a Class A digital device, pursuant to Part 15 of the FCC Rules. These limits are designed to provide reasonable protection against harmful interference when the equipment is operated in a commercial environment. This equipment generates, uses, and can radiate radio frequency energy and, if not installed and used in accordance with the instruction manual, may cause harmful interference to radio communications.

Operation of this equipment in a residential area is likely to cause harmful interference in which case the user will be required to correct the interference at his own expense.



In order to allow this equipment to operate in close proximity to Industrial, Scientific and Medical (ISM) equipment, the external radiation from ISM equipment may have to be limited or special mitigation measures taken.

Changes and modifications to this equipment not specifically approved by Xerox® may void the user's authority to operate this equipment.

Shielded cables must be used with this equipment to maintain compliance with FCC regulations.

GREAT BRITAIN

The UKCA mark applied to this product, symbolizes our declaration of conformity with the following applicable Great Britain Regulations, as of the dates indicated:



December 8, 2016:	Electrical Equipment (Safety) Regulations 2016
December 8, 2016:	Electromagnetic Compatibility Regulations 2016

A full declaration of conformity, defining the relevant directives and referenced standards, can be obtained from your Xerox Limited representative or by contacting:

Environment, Health and Safety
Xerox (UK)
Sanderson Road
Uxbridge UB8 1DH

EUROPEAN UNION

The CE mark applied to this product, symbolizes our declaration of conformity with the following applicable European Union Directives, as of the dates indicated:



September 8, 2017:	Council Directive 2014/35/EU as amended. Approximation of the laws of the member states related to low voltage equipment.
August 12, 2016:	Council Directive 2014/30/EU as amended. Approximation of the laws of the member states related to electromagnetic compatibility.

This machine is certified as Class 1 LED product. This means that this machine does not produce hazardous laser radiation.

A full declaration of conformity, defining the relevant directives and referenced standards, can be obtained from your Xerox Limited representative or by contacting:

Environment, Health and Safety
 Xerox(NL)
 Sint Jansweg 15
 NL-5928 RC
 VENLO

TURKEY (ROHS REGULATION)

In compliance with Article 7 (d) We hereby certify “It is in compliance with the EEE Regulation”.

(“EEE yönetmeliğine uygundur“)

Copy Regulations**UNITED STATES**

Congress, by statute, has forbidden the reproduction of the following subjects under certain circumstances. Penalties of fine or imprisonment may be imposed on those guilty of making such reproductions.

1. Obligations or Securities of the United States Government, such as:

Certificates of Indebtedness	National Bank Currency	Coupons from Bonds
Federal Reserve Bank Notes	Silver Certificates	Gold Certificates
United States Bonds	Treasury Notes	Federal Reserve Notes
Fractional Notes	Certificates of Deposit	Paper Money

Bonds and Obligations of certain agencies of the government, such as FHA, etc.

Bonds. (U.S. Savings Bonds may be photographed only for publicity purposes in connection with the campaign for the sale of such bonds.)

Internal Revenue Stamps. (If it is necessary to reproduce a legal document on which there is a canceled revenue stamp, this may be done provided the reproduction of the document is performed for lawful purposes.)

Postage Stamps, canceled or uncanceled. (For philatelic purposes, Postage Stamps may be photographed, provided the reproduction is in black and white and is less than 75% or more than 150% of the linear dimensions of the original.)

Postal Money Orders.

Bills, Checks, or Drafts of money drawn by or upon authorized officers of the United States.

Stamps and other representatives of value, of whatever denomination, which have been or may be issued under any Act of Congress.

2. Adjusted Compensation Certificates for Veterans of the World Wars.
3. Obligations or Securities of any Foreign Government, Bank, or Corporation.
4. Copyrighted material, unless permission of the copyright owner has been obtained or the reproduction falls within the "fair use" or library reproduction rights provisions of the copyright law. Further information of these provisions may be obtained from the Copyright Office, Library of Congress, Washington, D.C. 20559. Ask for Circular R21.
5. Certificates of Citizenship or Naturalization. (Foreign Naturalization Certificates may be photographed.)
6. Passports. (Foreign Passports may be photographed.)
7. Immigration Papers.
8. Draft Registration Cards.
9. Selective Service Induction Papers that bear any of the following Registrant's information:

Earnings or Income	Dependency Status	Court Record
Previous military service	Physical or mental condition	

Exception: U. S. Army and Navy discharge certificates may be photographed.

10. Badges, Identification Cards, Passes, or Insignia carried by military personnel, or by members of the various Federal Departments, such as FBI, Treasury, etc. (unless photograph is ordered by the head of such department or bureau.)
11. Reproducing the following is also prohibited in certain states: Automobile Licenses — Drivers' Licenses — Automobile Certificates of Title.

The above list is not all inclusive, and no liability is assumed for its completeness or accuracy. In case of doubt, consult your attorney.

CANADA

Parliament, by statute, has forbidden the reproduction of the following subjects under certain circumstances. Penalties of fines or imprisonment may be imposed on those guilty of making such copies.

1. Current bank notes or current paper money.
2. Obligations or securities of a government or bank.
3. Exchequer bill paper or revenue paper.
4. The public seal of Canada or of a province, or the seal of a public body or authority in Canada, or of a court of law.
5. Proclamations, orders, regulations or appointments, or notices thereof (with intent to falsely cause same to purport to have been printed by the Queen's Printer for Canada, or the equivalent printer for a province).
6. Marks, brands, seals, wrappers or designs used by or on behalf of the Government of Canada or of a province, the government of a state other than Canada or a department, board, Commission or agency established by the Government of Canada or of a province or of a government of a state other than Canada.
7. Impressed or adhesive stamps used for the purpose of revenue by the Government of Canada or of a province or by the government of a state other than Canada.
8. Documents, registers or records kept by public officials charged with the duty of making or issuing certified copies thereof, where the reproduction falsely purports to be a certified copy thereof.
9. Copyrighted material or trademarks of any manner or kind without the consent of the copyright or trademark owner.

The above list is provided for your convenience and assistance, but it is not all inclusive, and no liability is assumed for its completeness or accuracy. In case of doubt, consult your solicitor.

OTHER COUNTRIES

Copying certain documents may be illegal in your country. Penalties of fine or imprisonment may be imposed on those found guilty of making such reproductions.

- Currency notes
- Bank notes and cheques
- Bank and government bonds and securities
- Passports and identification cards
- Copyright material or trademarks without the consent of the owner
- Postage stamps and other negotiable instruments

Note: This list is not inclusive and no liability is assumed for either its completeness or accuracy. In case of doubt, contact your legal counsel.

8. Appendix B: Compliance Information

Product Recycling & Disposal

USA & CANADA

If you are managing the disposal of your Xerox® Product, please note that the product may contain lead, mercury, perchlorate, and other materials whose disposal may be regulated due to environmental considerations. The presence of these materials is fully consistent with global regulations applicable at the time that the product was placed on the market. For recycling and disposal information, contact your local authorities. In the United States, you may also refer to the Electronic Industries Alliance web site.

Perchlorate Material - This product may contain one or more Perchlorate-containing devices, such as batteries. Special handling may apply.

EUROPEAN UNION

RoHS Compliance and WEEE Compliance

This product is compliant with RoHS Regulations of the European Parliament and Council Directive on the Restrictions of the Use of Certain Hazardous Substances in Electrical and Electronic Equipment (2011/65/EU), and with the Waste Electrical and Electronic Equipment (WEEE) Directive (2012/19/EU).

Some equipment may be used in both a domestic/household and a professional/business application.

Professional/Business Environment

Application of this symbol on your equipment is confirmation that you must dispose of this equipment in compliance with agreed national procedures. In accordance with European legislation, end of life electrical and electronic equipment subject to disposal must be managed within agreed procedures.



ENERGY STAR for the USA

Energy Program Compliance

The Xerox® D35 Scanner is ENERGY STAR qualified under the ENERGY STAR Program Requirements for Imaging Equipment.



The ENERGY STAR and ENERGY STAR MARK are registered United States trademarks. The ENERGY STAR Imaging Equipment Program is a team effort between U.S., European Union and Japanese governments and the office equipment industry to promote energy-efficient copiers, printers, fax, multifunction machine, personal computers, and monitors. Reducing product energy consumption helps combat smog, acid rain and long-term changes to the climate by decreasing the emissions that result from generating electricity.

Xerox® equipment is preset at the factory. Your machine will be delivered with the timer for switching to Power Save Mode from the last scan set at 15 minutes.